

**DMV-D(LE) 704/604**  
**Dual Modular NEMA 4x Safety Shutoff Valves**  
**Installation Instructions**

**SPECIFICATIONS**

**DMV-D/604** Two normally closed automatic shutoff valves in one housing. V1 and V2 are fast opening, fast closing. Adjustable max. flow with V2.

**DMV-DLE/604** Two normally closed automatic shutoff valves in one housing. V1 fast opening, fast closing. V2 is slow opening, fast closing. Adjustable max. flow and adjustable initial lift with V2.

**Body size** Flange Size  
DMV-D(LE) 704/604 2" NPT/Rp

**Gases**  
Natural gas, propane, butane; & noncorrosive gases.  
Suitable for up to 0.1% by volume, dry H<sub>2</sub>S.

**Maximum Operating Pressure**

7 PSI (500 mbar)  
5 PSI (360 mbar) CSA

**Maximum Close-off Pressure**

10 PSI (750 mbar)

**Ambient / Fluid Temperature**

-20°F to +140°F; (-30°C to +60°C)

**Electrical Ratings**

110 to 120 Vac /50 to 60 Hz

**Power Consumption** with all coils energized

DMV-D(LE) 704 90 VA

**Electrical Connection**

Screw terminals with 1/2" NPT conduit connection

**Enclosure Rating**

NEMA Type 4x

**Max. Flow Setting** (DMV-D & DMV-DLE)

Adjustable on V2: < 10 to 100 % of total flow

**Initial Lift Adjustment** (DMV-DLE) only

Adjustable on V2: 0 to 70 % of total flow; 0 to 35% of stroke

**Materials in contact with Gas**

Housing: Aluminum, Steel; free of nonferrous metals.  
Sealings on valve seats: NBR-based rubber.

**Mounting Position**

Solenoid upright vertical  
to solenoid horizontal

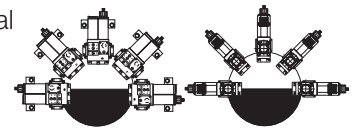

**Strainer**

23 Mesh, installed in the housing upstream V1

**Test Ports**

Taps available on both sides upstream of V1, between V1 and V2 and downstream of V2, and on both flanges. See page 3.

**Proof of Closure Switch** with visual indication

SPDT switch rated at 10 A res, 8 FLA, 48 LRA @120 V

**Position Indication**

Visual Indicator

CPI 400 valve switch with isual indication; SPDT switch rated at 10 A res, 8 FLA, 48 LRA @120 V.

**Classification of Valve V1 and V2**

Safety Shut Off Valve:  
ANSI Z21.21 • CSA 6.5 C/I Valves

**Approvals:**

CSA: Certified File No.112901  
Commonwealth of Massachusetts Approved Product  
Approval code G1-1107-35



**ATTENTION**

- Read these instructions carefully.
- Failure to follow them and/or improper installation may cause explosion, property damage and injuries.
- The system must meet all applicable national and local code requirements such as but not limited to the following fuel gas codes: NFPA 54, IFGC (International Fuel Gas Code), or CSA B149.1 (for Canada) or the following equipment codes and standards: CSD-1, NFPA 86, NFPA 37, ANSI Z83.4/CSA 3.7, ANSI Z83.18, ANSI Z21.13/ CSA 4.9, or CSA B149.3 (for Canada).
- Installation must be done with the supervision of a licensed burner technician.
- Check the ratings in the specifications to make sure that they are suitable for your application.
- Never perform work if gas pressure or power is applied, or in the presence of an open flame.
- Once installed, perform a complete checkout including leak testing.
- Verify proper operation after servicing.

## PAINTING VALVE

- It is not recommended that this valve be painted. Painting covers date codes and other labels that identify this valve.
- If the valve needs to be painted, a paint free of volatile organic components (VOC's) must be used. VOC's can damage valve o-rings, resulting in external gas leakage over time.
- During the painting process, use measures that will allow the valve's date code and other labeling information to be legible after the paint is dry.

## PROTECTION FROM RADIANT HEAT

- Radiant heat must be considered as a heat source that could result in an ambient temperature higher than the rating of this valve.
- Provide proper shielding to protect against radiant heat.

## MOUNTING

### DMV 704/604 Flange Mounting Procedure

- Remove the bolts that are holding the protective covers on the inlet and outlet of the DMV using a 13 mm wrench.
- Remove the two protective covers from the valve body.
- Make sure the O-rings and the grooves are clean and in good condition. Clean if necessary.
- Attach the flanges using the bolts supplied.
- Tighten the screws in a crisscross pattern.
- Do not overtighten the screws. Follow the maximum torque values below.

### Recommended Torque Screws

M8	Bolt Size
134	[lb-in]

### DMV 704/604 Pipe Mounting Procedure

- Install the valve with the gas flow matching the direction indicated by the arrows on the casting.
- Mount the DMV 704/604 with the solenoid vertical or horizontal.
- Use new, properly reamed and threaded pipe free of chips.
- Apply good quality pipe sealant, putting a moderate amount on the male threads only. If using LP gas, use pipe sealant rated for use with LP gas.
- Do not thread pipe too far. DMV 704/604 distortion and/or malfunction may result from excess pipe in the valve body.

- Apply counter pressure with a parallel jaw wrench only to the flats of the DMV 704/604 when installing pipe.
- Do not overtighten the pipe. Follow the maximum torque of 1190 lb-in.
- After installation is complete, perform a complete leak test.

### DMV 704/604

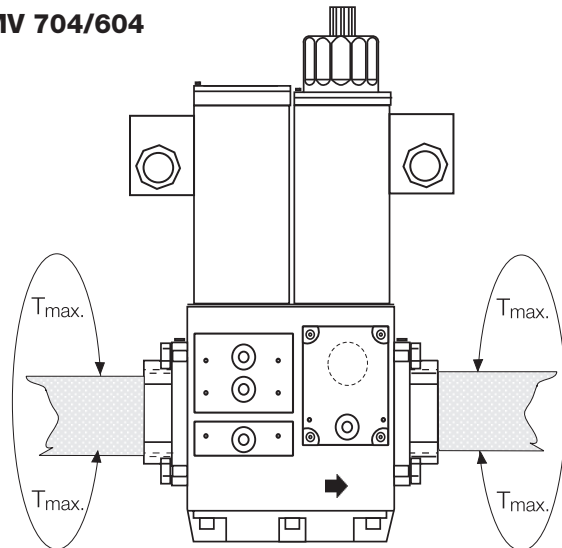

**CAUTION:** If the flow is not in the same direction of the arrows, the valves will not operate properly.

## WIRING

**NOTE: Use 14 or 16 guage wire rated for 95°C(200°F).**

- Remove the wiring box cover and knock out only one of the conduit connections on the side of the terminal box you wish to make your conduit connection to.
- Make electrical connections to the valve, replace cover.

**CAUTION:** All wiring must comply with local electrical codes, ordinances and regulations.

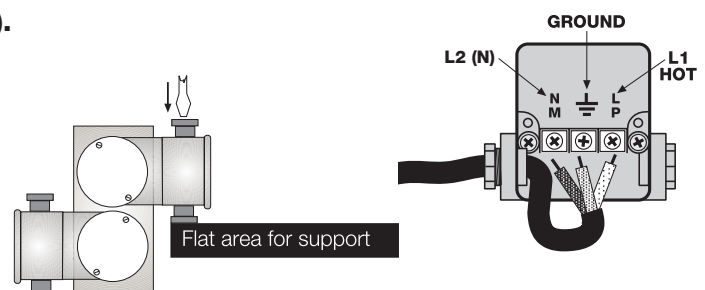

# VALVE ADJUSTMENT

## DMV 704/604 Flow Setting

- The valve is factory set with the flow adjustment fully open.
- Locate the flow adjustment on top of valve 2. There are two screws, the holding screw is recessed and has a blue sealing compound on it, while the pan head screw protrudes from the cap. Loosen the pan head screw until you can freely rotate the flow adjustment. Turn clockwise for less gas or counterclockwise for more gas. Check the flow at the burner with an orifice or flow meter.
- Tighten the pan head screw on the adjustment cap.

## Initial Lift Adjustment (DMV-DLE only)

The initial lift adjustment varies the initial gas flow through the valve as the valve seat begins to open. This adjustment can vary the initial flow between 0 % and 70% of the total gas flow; 0 to 35% of stroke. All DMV-DLE valves are factory set with no initial lift. To adjust the lift proceed as follows:

- Unscrew the small black cap on top of the silver hydraulic brake to expose the initial lift adjustment knob.
- The black cap also serves as tool; turn the cap over and insert it on the slot on the adjustment knob.
- Turn the knob clockwise for a min. initial lift or counterclockwise for a max. initial lift.
- Once the desired initial fast lift has been achieved, reinstall the black cap.

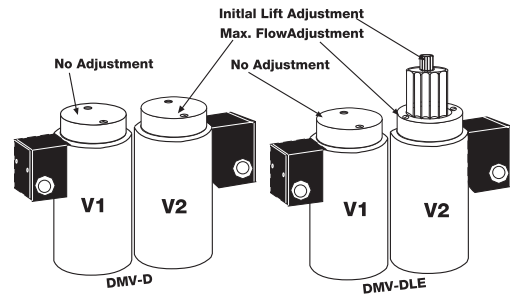

**CAUTION:** Do not adjust or remove any screws or bolts which are sealed with a Red colored compound. Doing so will void all approvals and

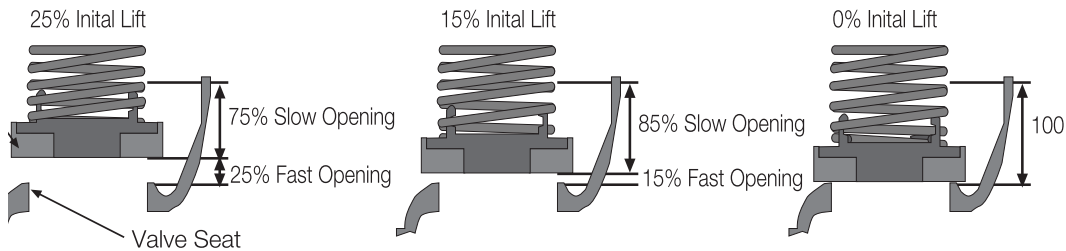
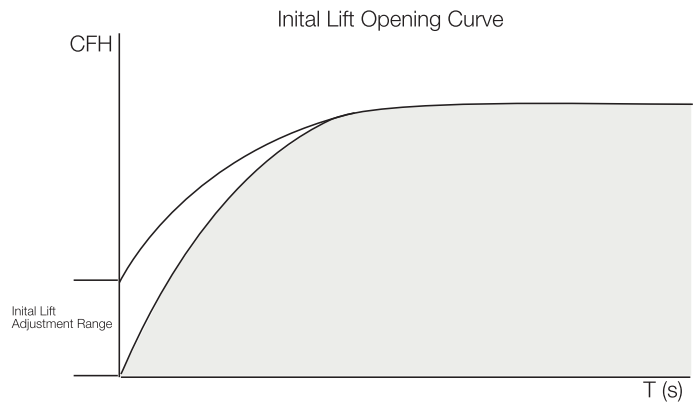

# SIDE TAPS

## DMV 704/604 Side Taps

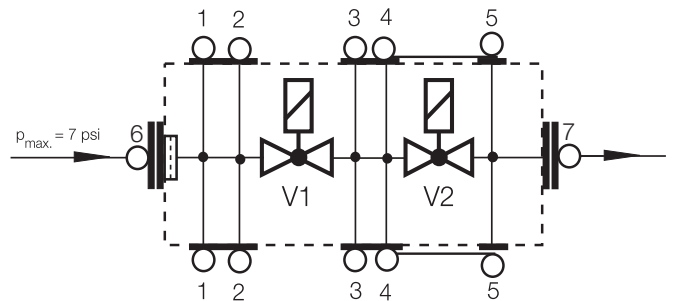
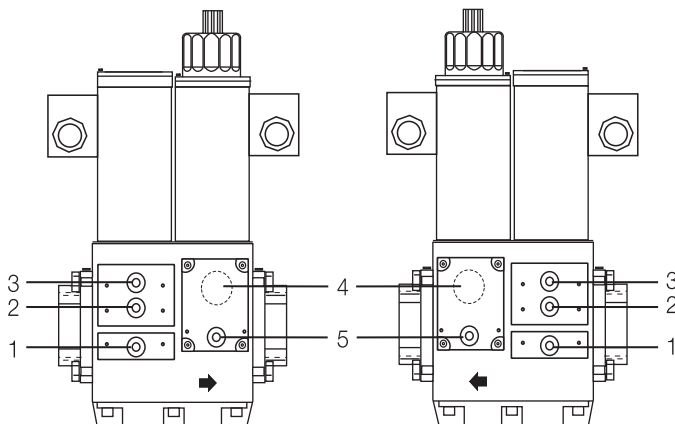

## VALVE LEAKAGE TEST

This leak test procedure tests the external sealing and valve seat sealing capabilities of the DMV automatic safety shutoff valve. Only qualified personnel should perform this test.

It is required that this test be done on the initial system start-up, and then repeated at least annually. Possibly more often depending on the application, environmental parameters, and the requirements of the authority having jurisdiction.

### SETUP

This test requires the following:

- A) Test nipples installed in the downstream pressure tap port of each automatic safety shutoff valve to make the required 1/4" hose connection in step 4.
- B) A transparent glass of water filled at least 1 inch from the bottom.
- C) A proper leak test tube. An aluminum or copper 1/4" rigid tube with a 45° cut at the end that is then connected to a 1/4" flexible hose of some conven

### LEAK TEST PROCEDURE

Use the illustration below as a reference.

1. With the upstream ball valve open, the downstream ball valve closed and both valves energized, apply an all purpose liquid leak detector solution to the "External Leakage Test Areas" indicated in the illustration below, to any accessories mounted to the safety valve, and to all gas piping and gas components downstream the equipment isolation valve, and the inlet and outlet gas piping of the automatic safety shutoff valve. The presence of bubbles indicates a leak, which needs to be rectified before proceeding.

2. Then, de-energize the burner system and verify that both automatic safety shutoff valves are closed.
3. Close the upstream and downstream manual ball valve.
4. Using a screwdriver, slowly open the V1 test nipple (port 3) by turning it counter clockwise to depressurize the volume between the two valves, and connect the 1/4" flexible hose to the test nipple.
5. Slowly open the upstream manual ball valve, and then provide for some time to allow potential leakage to charge the test chamber before measuring the valve seat leakage.
6. Immerse the 1/4 in. tube vertically 1/2 in. (12.7 mm) below the water surface. If bubbles emerge from the 1/4" tube and after the leakage rate has stabilized, count the number of bubbles appearing during a 10 second period. (See chart below for allowable leakage rates.)
7. Repeat the same procedure for valve V2 (port 5), except that valve #1 needs to be opened.

### After completing the above tests proceed as follows:

8. Verify that the downstream manual ball valve is closed, and both automatic safety shutoff valves are de-energized.
9. Remove the flexible hose, and close all test nipples.
10. With the upstream manual ball valve open, energize both automatic safety shutoff valves.
11. Use soapy water to leak test all test nipples to ensure that there are no leaks.
12. If no leakage is detected, de-energize all automatic safety shutoff valves, and open the downstream manual ball valve.

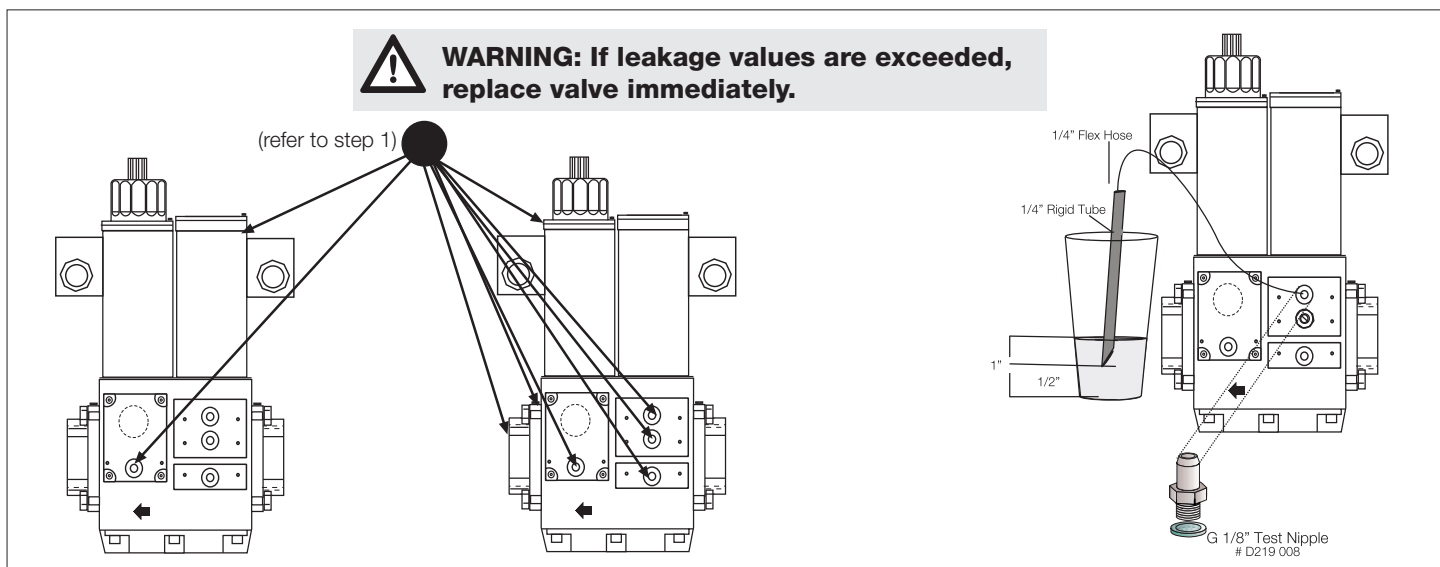

### Type

### Allowable Valve Seat Leakage\* for up to 7 PSI inlet

### # of Bubbles in 10 sec AIR    Natural Gas    LP

DMV D(LE) 704/604

628 cc/hr

12

15

9

\*Based on air, and test conditions per UL 429 Section 29. (Air or inert gas at a pressure of 1/4 psig and also at a pressure of one and one-half times maximum operating pressure differential, but not less than 1/2 psig. This test shall be applied with the valve installed in its intended position.) Volume of bubble defined in Table 2 of FCI 70-2-1998.

# FLOW CURVE

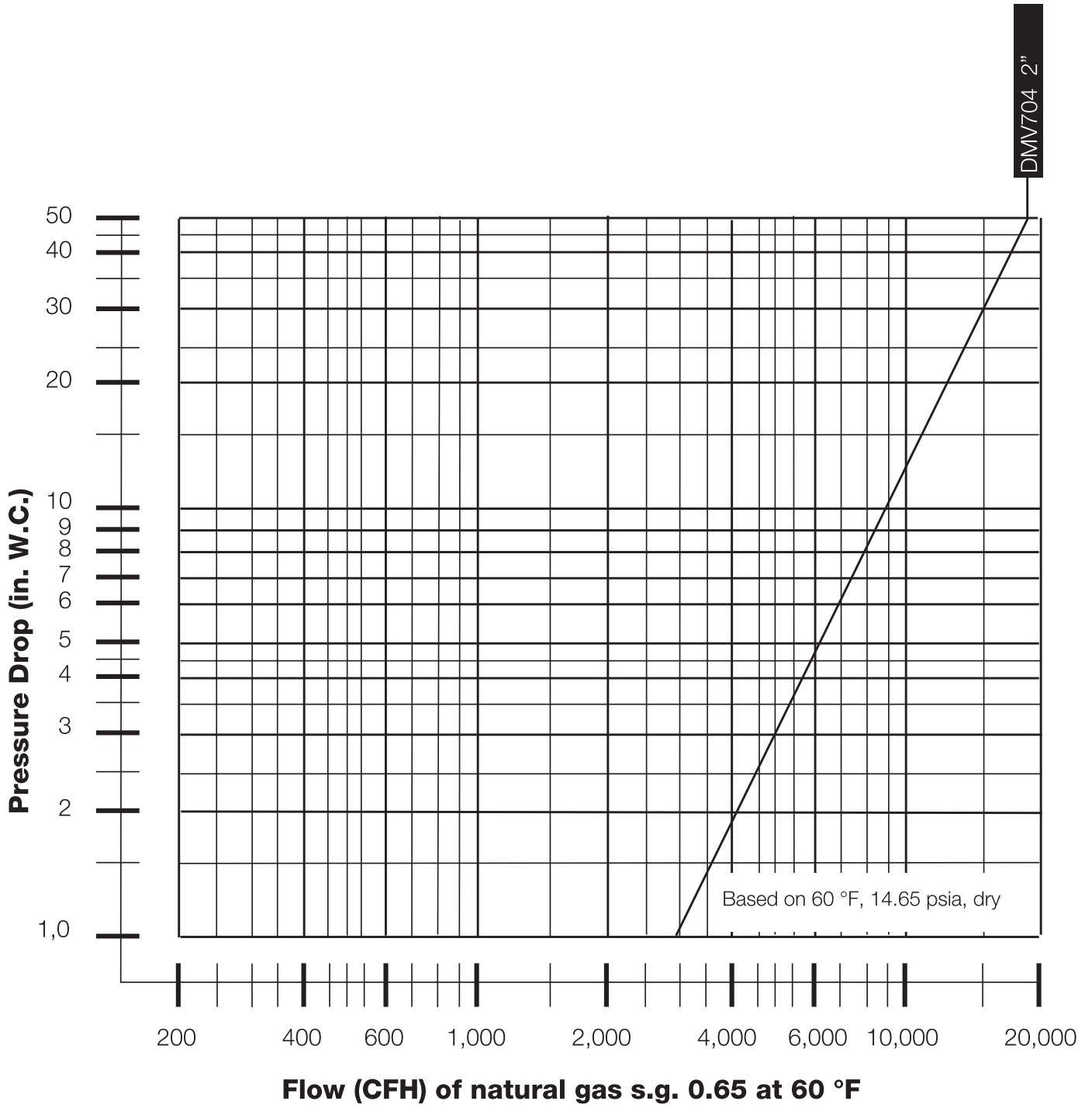

## PRESSURE DROP FOR OTHER GASES

To determine the pressure drop when using a gas other than natural gas, use the flow formula below and f value located in the chart below to determine the “corrected” flow rate in CFH through the valve for the other gas used. For example, when using propane, divide the volume (CFH) of propane required for the application by the calculated value f (f = 0.66 for propane). Use this “corrected” flow rate and the flow curve on the previous page to determine pressure drop for propane.

$$\dot{V}_{\text{gas used}} = \dot{V}_{\text{Natural Gas}} \times f$$

Use this formula to calculate the f factor for other gases not listed on the table.

$$f = \sqrt{\frac{\text{Spec. gravity of Natural Gas}}{\text{Spec. gravity of gas used}}}$$

Type of gas used	Density [kg/m <sup>3</sup> ]	sg	f
Natural gas	0.81	0.65	1.00
Butane	2.39	1.95	0.58
Propane	1.86	1.50	0.66
Air	1.24	1.00	0.80

## ACCESSORIES AND REPLACEMENT PARTS

Description	Part #
<b>Visual Indicator</b>	217-665
<b>CPI 400 valve switch</b>	224-253A
<b>DMV-D(LE) 704 gasket for flange</b>	231-574
<b>2" NPT Flange</b>	232-407
<b>2" Rp Flange</b>	215-384
<b>120Vac Replacement Coil (Mag. Type 201)</b>	246-517
<b>Vent Line Adapter - 1" NPT (field mountable)</b>	243-760
<b>G1/8" test nipple</b>	219-008